

GEMÜ 675

Manually operated diaphragm valve



Features

- Suitable for particulate and abrasive media
- Various lining materials are available for a wide range of media
- Standard integral optical position indicator

Description

The GEMÜ 675 2/2-way diaphragm valve has a metal handwheel and is manually operated. An integral optical position indicator is standard.

Technical specifications

- Media temperature: -10 to 100 °C
 - Ambient temperature*: 0 to 60 °C
 - Operating pressure*: 0 to 10 bar
 - Nominal sizes*: DN 15 to 150
 - Body configurations: 2/2-way body
 - Connection types: Flange | Threaded connection
 - Connection standards: ANSI | BS | DIN | EN
 - Body materials: EN-GJL-250, cast iron material | EN-GJS-400-18-LT, SG iron material | EN-GJS-500-7, ductile iron material
 - Body lining: Hard rubber | PFA | PP
 - Diaphragm materials: CR | EPDM | FKM | NBR | PTFE/EPDM
 - Conformities*: EAC | FDA | Reg. (EU) No. 10/2011 | Regulation (EC) No. 1935/2004 | TA Luft (German Clean Air Act)
- * depending on version and/or operating parameters



Product description

Construction

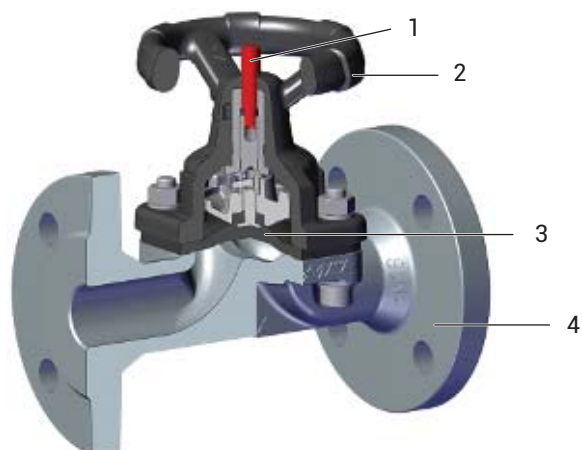

Item	Name	Materials
1	Optical position indicator	PP red
2	Actuator	Cast iron
3	Diaphragm	CR EPDM FKM NBR PTFE / EPDM (one-piece) PTFE / EPDM (two-piece)
4	Valve body	EN-GJL-250 (GG 25) EN-GJS-400-18-LT (GGG 40.3), PFA lined EN-GJS-400-18-LT (GGG 40.3), PP lined EN-GJS-400-18-LT (GGG 40.3), hard rubber lined EN-GJS-500-7 (GGG 50), PFA lined EN-GJS-500-7 (GGG 50), PP lined

Availability

Availability of valve bodies

Threaded connection, flange

MG	DN	Threaded connection	Flange																		
			Connection types code ¹⁾																		
			1	8			38			39			51		53		56				
			Material code ²⁾																		
	8	8	17	18	83	17	18	83	8	17	18	83	17	81	91	8	17	17	81	91	
25	15	X	X	X	X	X	-	-	-	X	X	X	X	-	-	-	X	-	-	-	-
	20	X	X	X	X	X	X	X ³⁾	X	X	X	X	X	-	-	-	X	-	-	-	-
	25	X	X	X	X	X	X	X ³⁾	X	X	X	X	X	-	X	X ⁴⁾	X	-	-	X	X ⁵⁾
40	32	X	X	X	X	X	-	-	-	X	X	X	X	-	-	-	-	-	-	-	-
	40	X	X	X	X	X	X	X ³⁾	X	X	X	X	X	-	X	X ⁴⁾	X	-	-	X	X ⁵⁾
50	50	X	X	X	X	X	X	X ³⁾	X	X	X	X	X	-	X	X ⁴⁾	X	-	-	X	X ⁵⁾
65	65	-	X	X	X	X	X	X ³⁾	X	X	X	X	X	-	-	-	X	-	-	-	-
80	80	-	X	X	X	X	X	X ³⁾	X	X	X	X	X	-	X	X ⁴⁾	X	-	-	X	X ⁵⁾
100	100	-	X	X	X	X	X	X ³⁾	X	-	X	X	X	-	X	X ⁴⁾	X	-	-	X	X ⁵⁾
125	125	-	X	X	-	X	-	-	-	X	X	-	X	-	-	-	X	-	-	-	-
150	150	-	X	X	-	X	X	-	X	X	X	-	X	X	-	-	X	X	X	-	-

MG = diaphragm size

X = Standard

1) Connection type

Code 1: Threaded socket DIN ISO 228

Code 8: Flange EN 1092, PN 16, form B, face-to-face dimension FTF EN 558 series 1, ISO 5752, basic series 1, length only for body configuration D

Code 38: Flange ANSI Class 150 RF, face-to-face dimension FTF MSS SP-88, length only for body configuration D

Code 39: Flange ANSI Class 125/150 RF, face-to-face dimension FTF EN 558 series 1, ISO 5752, basic series 1, length only for body configuration D

Code 51: Flange BS 10 Table "E", face-to-face dimension FTF EN 558 series 7, ISO 5752, basic series 7, length only for body configuration D

Code 53: Flange EN 1092, PN 16, form A, face-to-face dimension FTF EN 558 series 7, ISO 5752, basic series 7, length only for body configuration D

Code 56: Flange ANSI Class 125/150 RF, face-to-face dimension FTF EN 558 series 7, ISO 5752, basic series 7, length only for body configuration D

2) Valve body material

Code 8: EN-GJL-250 (GG 25)

Code 17: EN-GJS-400-18-LT (GGG 40.3), PFA lined

Code 18: EN-GJS-400-18-LT (GGG 40.3), PP lined

Code 81: EN-GJS-500-7 (GGG 50), PFA lined

Code 83: EN-GJS-400-18-LT (GGG 40.3), hard rubber lined

Code 91: EN-GJS-500-7 (GGG 50), PP lined

3) Connection code 38 / material code 18 on request

4) Connection code 51 / material code 91 on request

5) Connection code 56 / material code 91 on request

Availability of product compliance

	Diaphragm material code ¹⁾	Body material code ²⁾
Food		
FDA	54, 5M	17, 81
TA Luft (German Clean Air Act)		
TA Luft (German Clean Air Act)		17, 18, 81, 91

1) **Diaphragm material**

Code 54: PTFE/EPDM one-piece

Code 5M: PTFE/EPDM two-piece

2) **Valve body material**

Code 17: EN-GJS-400-18-LT (GGG 40.3), PFA lined

Code 18: EN-GJS-400-18-LT (GGG 40.3), PP lined

Code 81: EN-GJS-500-7 (GGG 50), PFA lined

Code 91: EN-GJS-500-7 (GGG 50), PP lined

Availability of actuator version

MG	DN	Actuator version
25	15 – 25	0
40	32 – 40	1
50	50	2
65	65	3
80	80	4
100	100	5
125	125	6
150	150	7

Order data

The order data provide an overview of standard configurations.

Please check the availability before ordering. Other configurations available on request.

Order codes

1 Type	Code
Diaphragm valve, manually operated, metal handwheel, metal distance piece, optical position indicator	675

2 DN	Code
DN 15	15
DN 20	20
DN 25	25
DN 32	32
DN 40	40
DN 50	50
DN 65	65
DN 80	80
DN 100	100
DN 125	125
DN 150	150

3 Body configuration	Code
2/2-way body	D

4 Connection type	Code
Threaded connection	
Threaded socket DIN ISO 228	1
Flange	
Flange EN 1092, PN 16, form B, face-to-face dimension FTF EN 558 series 1, ISO 5752, basic series 1, length only for body configuration D	8
Flange ANSI Class 150 RF, face-to-face dimension FTF MSS SP-88, length only for body configuration D	38
Flange ANSI Class 125/150 RF, face-to-face dimension FTF EN 558 series 1, ISO 5752, basic series 1, length only for body configuration D	39
Flange BS 10 Table "E", face-to-face dimension FTF EN 558 series 7, ISO 5752, basic series 7, length only for body configuration D	51
Flange EN 1092, PN 16, form A, face-to-face dimension FTF EN 558 series 7, ISO 5752, basic series 7, length only for body configuration D	53
Flange ANSI Class 125/150 RF, face-to-face dimension FTF EN 558 series 7, ISO 5752, basic series 7, length only for body configuration D	56

5 Valve body material	Code
EN-GJL-250 (GG 25)	8
EN-GJS-400-18-LT (GGG 40.3), PFA lined	17
EN-GJS-400-18-LT (GGG 40.3), PP lined	18
EN-GJS-500-7 (GGG 50), PFA lined	81
EN-GJS-400-18-LT (GGG 40.3), hard rubber lined	83
EN-GJS-500-7 (GGG 50), PP lined	91

6 Diaphragm material	Code
NBR	2
FPM	4
CR	8
EPDM	14
PTFE/EPDM one-piece	54
PTFE/EPDM two-piece	5M

7 Control function	Code
Manually operated	0
Manually operated, with lockable handwheel	L
Manually operated with lockable handwheel, (without proprietary padlock)	B

8 Actuator version	Code
DN 15 - 25, diaphragm size 25	
Actuator size 0	0
DN 32 - 40, diaphragm size 40	
Actuator size 1	1
DN 50, diaphragm size 50	
Actuator size 2	2
DN 65, diaphragm size 65	
Actuator size 3	3
DN 80, diaphragm size 80	
Actuator size 4	4
DN 100, diaphragm size 100	
Actuator size 5	5
DN 125, diaphragm size 125	
Actuator size 6	6
DN 150, diaphragm size 150	
Actuator size 7	7

Order example

Order option	Code	Description
1 Type	675	Diaphragm valve, manually operated, metal handwheel, metal distance piece, optical position indicator
2 DN	50	DN 50
3 Body configuration	D	2/2-way body
4 Connection type	8	Flange EN 1092, PN 16, form B, face-to-face dimension FTF EN 558 series 1, ISO 5752, basic series 1, length only for body configuration D
5 Valve body material	8	EN-GJL-250 (GG 25)
6 Diaphragm material	14	EPDM
7 Control function	0	Manually operated
8 Actuator version	2	Actuator size 2

Technical data

Medium

Working medium: Corrosive, inert, gaseous and liquid media which have no negative impact on the physical and chemical properties of the body and diaphragm material.

Temperature

Media temperature:

NBR (code 2)	-10 to 100 °C
FPM (code 4)	-10 to 90 °C
CR (code 8)	-10 to 100 °C
EPDM (code 14)	-10 to 90 °C
PTFE / EPDM (code 54)	-10 to 100 °C
PTFE / EPDM (code 5M)	-10 to 100 °C

Ambient temperature: 0 to 60 °C

Storage temperature: 0 to 40 °C

Pressure

Operating pressure:

MG	DN	EPDM	PTFE
25	15 - 25	0 - 10	0 - 6
40	32, 40	0 - 10	0 - 6
50	50	0 - 10	0 - 6
65	65	0 - 10	0 - 6
80	80	0 - 10	0 - 6
100	100	0 - 10	0 - 6
125	125	0 - 10	0 - 6
150	150	0 - 8	0 - 5

MG = diaphragm size

All pressures are gauge pressures. Operating pressure values were determined with static operating pressure applied on one side of a closed valve. Sealing at the valve seat and atmospheric sealing is ensured for the given values.

Information on operating pressures applied on both sides and for high purity media on request.

Pressure rating: PN 16

Leakage rate: Leakage rate A (acc. to EN 12266-1)

Kv values:

MG	DN	GG 25	PFA / PP	Hard rubber
25	15	7	5	6
	20	14	9	11
	25	20	13	15
40	32	36	23	29
	40	40	26	32
50	50	80	47	64
65	65	100	72	80
80	80	160	110	128
100	100	238	177	190
125	125	270	214	230
150	150	480	365	397

MG = diaphragm size, Kv values in m³/h

Kv values determined in accordance with EN 60534, inlet pressure 5 bar, Δp 1 bar, with connection flange EN 1092 length EN 558 series 1 and soft elastomer diaphragm. The Kv values for other product configurations (e.g. other diaphragm or body materials) may differ. In general, all diaphragms are subject to the influences of pressure, temperature, the process and their tightening torques. Therefore the Kv values may exceed the tolerance limits of the standard.

The Kv value curve (Kv value dependent on valve stroke) can vary depending on the diaphragm material and duration of use.

Product compliance

Pressure Equipment Directive: 2014/68/EU

Food: FDA*
Regulation (EC) No. 1935/2004*
Regulation (EC) No. 10/2011*

EAC: TR CU 010/2011

TA Luft (German Clean Air Act): The product complies with the equivalence requirements of section 5.2.6.4 of the German Clean Air Act (TA Luft / VDI 2440 according to section 3.3.1.3)*

The product complies with the requirements according to VDI 2440 (November 2000), VDI 3479, DIN EN ISO 158481, certificate no. 18 11 090235 002*

* see availability

Mechanical data

Weight:

Actuator

Actuator version	Weight
0	1.0
1	1.8
2	2.7
3	5.9
4	7.6
5	11.3
6	15.0
7	25.0

Weights in kg

Weight:

Body

MG	DN	Threaded socket	Flange
		Connection types code	
		1	8, 38, 39, 51, 53, 56
25	15	0.5	1.9
	20	0.6	2.4
	25	0.9	2.9
40	32	1.2	4.9
	40	1.8	5.7
50	50	2.6	7.5
65	65	-	10.2
80	80	-	14.2
100	100	-	21.0
125	125	-	30.0
150	150	-	35.0

MG = diaphragm size, weight in kg

Dimensions

Actuator dimensions

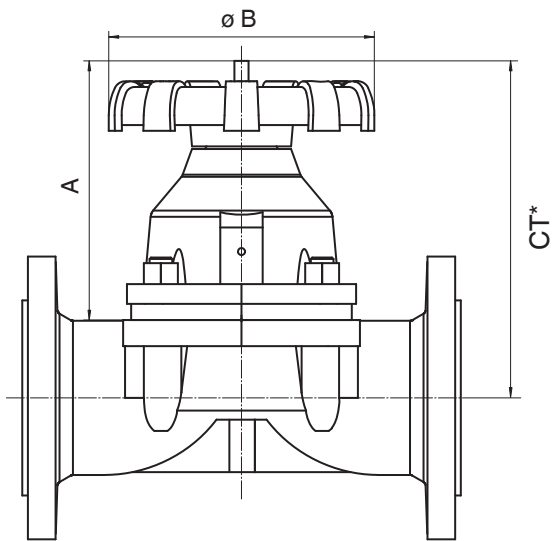

MG	DN	Actuator version	ø B	A
25	15 - 25	0	96	89
40	32 - 40	1	131	112
50	50	2	131	126
65	65	3	188	171
80	80	4	231	202
100	100	5	231	221
125	125	6	316	300
150	150	7	316	325

Dimensions in mm, MG = diaphragm size
 * CT = A + H1 (see body dimensions)

Body dimensions

Flange EN (code 8)

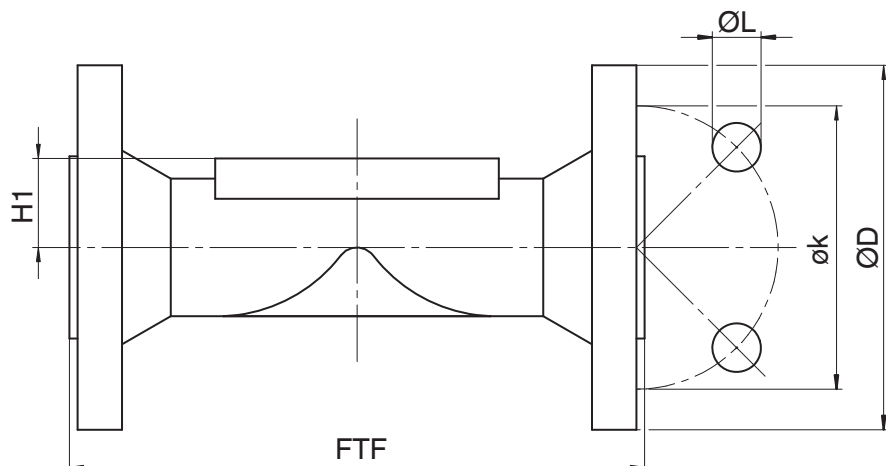

MG	DN	Connection type code 8 ¹⁾						
		Material code ²⁾						
						8	17, 18, 83	
		øD	øk	øL	n	H1	H1	FTF
25	15	95.0	65.0	14.0	4	19.0	18.0	130.0
	20	105.0	75.0	14.0	4	19.0	20.5	150.0
	25	115.0	85.0	14.0	4	19.0	23.0	160.0
40	32	140.0	100.0	19.0	4	28.0	28.7	180.0
	40	150.0	110.0	19.0	4	28.0	33.0	200.0
50	50	165.0	125.0	19.0	4	35.0	39.0	230.0
65	65	185.0	145.0	19.0	4	27.5	51.0	290.0
80	80	200.0	160.0	19.0	8	33.0	59.5	310.0
100	100	220.0	180.0	19.0	8	43.0	73.0	350.0
125	125	250.0	210.0	19.0	8	65.0	87.0	400.0
150	150	285.0	240.0	23.0	8	58.0	109.0	480.0

Dimensions in mm, MG = diaphragm size

n = number of bolt holes

1) Connection type

Code 8: Flange EN 1092, PN 16, form B, face-to-face dimension FTF EN 558 series 1, ISO 5752, basic series 1, length only for body configuration D

2) Valve body material

Code 8: EN-GJL-250 (GG 25)

Code 17: EN-GJS-400-18-LT (GGG 40.3), PFA lined

Code 18: EN-GJS-400-18-LT (GGG 40.3), PP lined

Code 83: EN-GJS-400-18-LT (GGG 40.3), hard rubber lined

Flange EN (code 53)

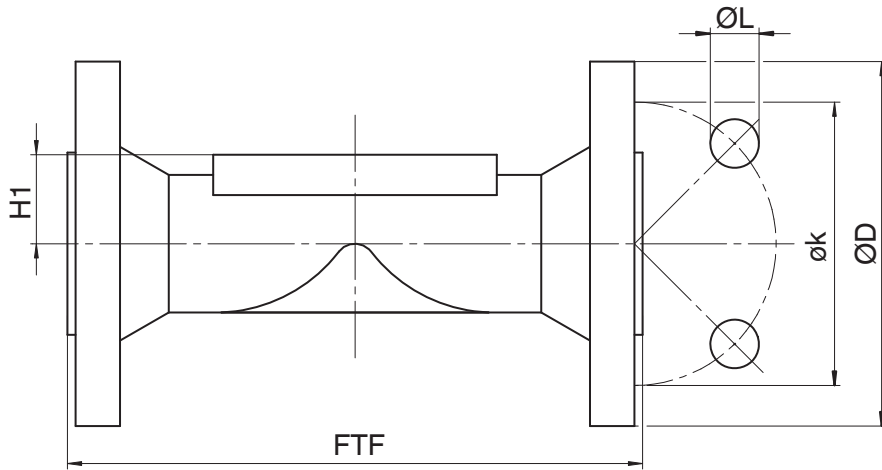

MG	DN	Connection type code 53 ¹⁾								
		Material code ²⁾								
		8	17				8	17	8	17
		øD	øD	øk	øL	n	H1	H1	FTF	FTF
25	15	95.0	-	65.0	14.0	4	19.0	-	117.0	-
	20	105.0	-	75.0	14.0	4	19.0	-	117.0	-
	25	115.0	-	85.0	14.0	4	19.0	-	127.0	-
40	32	140.0	-	100.0	19.0	4	28.0	-	-	-
	40	150.0	-	110.0	19.0	4	28.0	-	159.0	-
50	50	165.0	-	125.0	19.0	4	35.0	-	191.0	-
65	65	185.0	-	145.0	19.0	4	27.5	-	216.0	-
80	80	200.0	-	160.0	19.0	8	33.0	-	254.0	-
100	100	220.0	-	180.0	19.0	8	43.0	-	305.0	-
125	125	250.0	-	210.0	19.0	8	65.0	-	356.0	-
150	150	285.0	280,0 ³⁾	240.0	23.0	8	58.0	109.0	406.0	416.0

Dimensions in mm, MG = diaphragm size
n = number of bolt holes

- 1) **Connection type**
Code 53: Flange EN 1092, PN 16, form A, face-to-face dimension FTF EN 558 series 7, ISO 5752, basic series 7, length only for body configuration D
- 2) **Valve body material**
Code 8: EN-GJL-250 (GG 25)
Code 17: EN-GJS-400-18-LT (GGG 40.3), PFA lined
- 3) Diameter deviates from standard

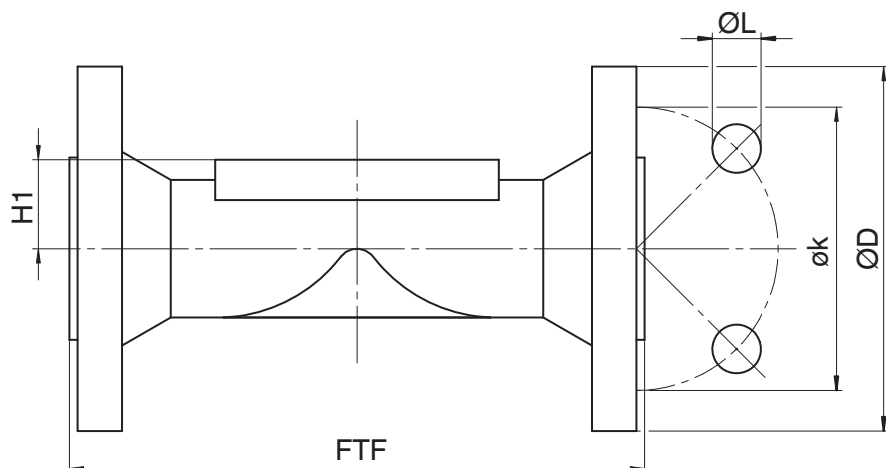
Flange ANSI Class (code 38, 39)

MG	DN	Connection types code ¹⁾								
								38	38	39
		Material code ²⁾								
					8	17, 18, 83	17, 18	83	8, 17, 18, 83	
		øD	øk	øL	n	H1	H1	FTF	FTF	FTF
25	15	90.0	60.3	15.9	4	19.0	18.0	-	-	130.0
	20	100.0	69.9	15.9	4	19.0	20.5	146.0	146.4	150.0
	25	110.0	79.4	15.9	4	19.0	23.0	146.0	146.4	160.0
40	32	115.0	88.9	15.9	4	28.0	28.7	-	-	180.0
	40	125.0	98.4	15.9	4	28.0	33.0	175.0	171.4	200.0
50	50	150.0	120.7	19.0	4	35.0	39.0	200.0	197.4	230.0
65	65	180.0	139.7	19.0	4	27.5	51.0	226.0	222.4	290.0
80	80	190.0	152.4	19.0	4	33.0	59.5	260.0	260.4	310.0
100	100	230.0	190.5	19.0	8	43.0	73.0	327.0	324.4	350.0
125	125	255.0	215.9	22.2	8	65.0	87.0	-	-	400.0
150	150	280.0	241.3	22.2	8	58.0	109.0	416.0	416.0	480.0

Dimensions in mm, MG = diaphragm size

n = number of bolt holes

1) **Connection type**

Code 38: Flange ANSI Class 150 RF, face-to-face dimension FTF MSS SP-88, length only for body configuration D

Code 39: Flange ANSI Class 125/150 RF, face-to-face dimension FTF EN 558 series 1, ISO 5752, basic series 1, length only for body configuration D

2) **Valve body material**

Code 8: EN-GJL-250 (GG 25)

Code 17: EN-GJS-400-18-LT (GGG 40.3), PFA lined

Code 18: EN-GJS-400-18-LT (GGG 40.3), PP lined

Code 83: EN-GJS-400-18-LT (GGG 40.3), hard rubber lined

Flange ANSI Class (code 56)

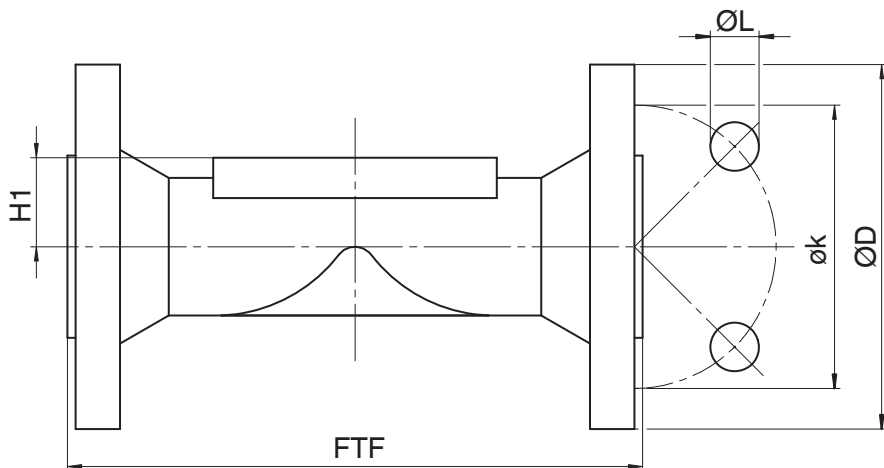

MG	DN	Connection type code 56 ¹⁾									
		Material code ²⁾						17	81, 91	17	81, 91
		øD	øk	øL	n	H1	H1	FTF	FTF		
25	25	110.0	79.4	15.9	4	-	23.0	-	127.0		
40	40	125.0	98.4	15.9	4	-	32.0	-	165.0		
50	50	150.0	120.7	19.0	4	-	40.0	-	191.0		
80	80	190.0	152.4	19.0	4	-	58.0	-	254.0		
100	100	230.0	190.5	19.0	8	-	70.0	-	311.0		
150	150	280.0	241.3	22.2	8	109.0	-	416.0	-		

Dimensions in mm, MG = diaphragm size

n = number of bolt holes

1) **Connection type**

Code 56: Flange ANSI Class 125/150 RF, face-to-face dimension FTF EN 558 series 7, ISO 5752, basic series 7, length only for body configuration D

2) **Valve body material**

Code 17: EN-GJS-400-18-LT (GGG 40.3), PFA lined

Code 81: EN-GJS-500-7 (GGG 50), PFA lined

Code 91: EN-GJS-500-7 (GGG 50), PP lined

Flange BS (code 51)

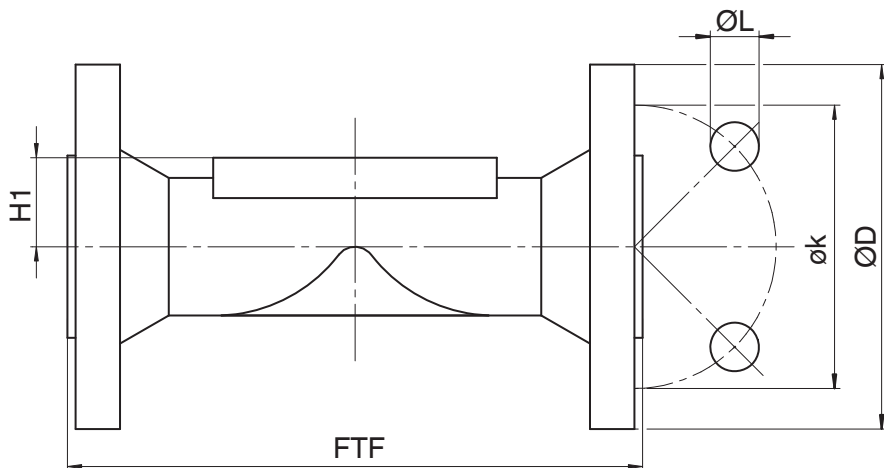

MG	DN	Connection type code 51 ¹⁾									
		Material code ²⁾						17	81, 91	17	81, 91
		øD	øk	øL	n	H1	H1	FTF	FTF		
25	25	114.0	83.0	14.0	4	-	23.0	-	127.0		
40	40	125.0 ³⁾	98.0	14.0	4	-	32.0	-	165.0		
50	50	152.0	114.0	17.0	4	-	40.0	-	191.0		
80	80	184.0	146.0	17.0	4	-	58.0	-	254.0		
100	100	216.0	178.0	17.0	8	-	70.0	-	311.0		
150	150	279.0	235.0	22.0	8	109.0	-	416.0	-		

Dimensions in mm, MG = diaphragm size

n = number of bolt holes

1) **Connection type**

Code 51: Flange BS 10 Table "E", face-to-face dimension FTF EN 558 series 7, ISO 5752, basic series 7, length only for body configuration D

2) **Valve body material**

Code 17: EN-GJS-400-18-LT (GGG 40.3), PFA lined

Code 81: EN-GJS-500-7 (GGG 50), PFA lined

Code 91: EN-GJS-500-7 (GGG 50), PP lined

3) Diameter deviates from standard BS 10

Threaded socket DIN (code 1)

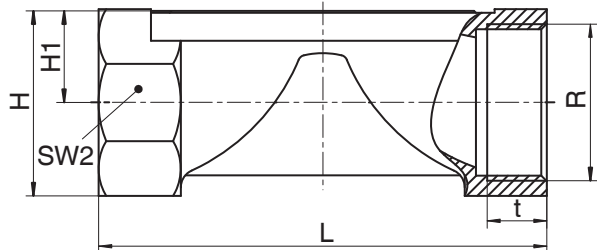

MG	DN	Connection type code 1 ¹⁾						
		Material code 8 ²⁾						
		R	H	H1	t	L	SW 2	n
25	15	G 1/2	35.0	19.0	12.0	85.0	32	6
	20	G 3/4	40.0	19.0	13.0	85.0	41	6
	25	G 1	42.0	19.0	16.0	110.0	46	6
40	32	G 1¼	56.0	28.0	16.0	120.0	55	6
	40	G 1½	61.0	28.0	18.0	140.0	65	6
50	50	G 2	73.0	35.0	18.0	165.0	75	6

Dimensions in mm, MG = diaphragm size

n = number of flats

1) **Connection type**

Code 1: Threaded socket DIN ISO 228

2) **Valve body material**

Code 8: EN-GJL-250 (GG 25)